



Liebert®

EXL S1  
from 100 to 1200 kW

Enhanced Design and Improved Efficiency



## Vertiv™

Vertiv designs, builds and services mission critical technologies that enable the vital applications for data centers, communication networks, and commercial and industrial environments. We support today's growing mobile and cloud computing markets with our portfolio of power, thermal, infrastructure management products, software and solutions, all complemented by our global service network. Bringing together global reach and local knowledge, and our decades-long heritage including brands like Chloride®, Liebert®, NetSure™ and Trellis™, our team of experts is ready to take on your most complex challenges, creating solutions that keep your systems running—and your business moving. Together, we're building the future of a world where critical technologies always work.

*YOUR VISION, OUR PASSION.*

**VertivCo.com**



## Liebert® EXL S1 from 100 to 1200 kW

### Liebert® EXL the New T-free Monolithic UPS Generation Delivering Secure Power and Maximized Energy Saving

Liebert EXL, the new generation of 80-NET UPS, delivers unsurpassed performance to medium-large data centers as a result of proven track record, successes, a reliable large installed base and more than 10 years of acquired experience with the 80-NET technology.

The new Liebert EXL is a monolithic product that features a transformer-free design with a full IGBT three-level topology. It provides extraordinary features, including a double conversion efficiency of up to 97%, further improved to 99% with the dynamic online mode. Moreover, the intelligent paralleling optimizes efficiency at partial load, achieving superior running cost savings as well as reduced TCO and CO<sub>2</sub> emissions.

Liebert EXL can operate with both standard VRLA and new Li-ion batteries thus adapting to all possible requirements in terms of runtime, life expectancy and TCO, and showing extreme flexibility.

Furthermore, its higher power density in a minimum footprint optimizes the availability of IT space and reduces related costs.

Liebert EXL, available from 100 to 1200 kW, delivers secure power while providing first class load protection and maximum energy saving for mission critical applications.

#### HIGHLIGHTS

- ✘ Extraordinary double conversion efficiency up to 97%
- ✘ Dynamic Online mode for highest availability and up to 99% efficiency
- ✘ Intelligent ECO mode efficiency above 99%
- ✘ Intelligent paralleling feature optimizes efficiency at partial load
- ✘ Maximized active power at unity power factor
- ✘ Compact footprint for optimum space utilization
- ✘ Backward compatibility with previous 80-NET generation
- ✘ Li-ion battery option to adapt to all scenarios



**WORLDWIDE**



## Capacity & Installation Flexibility from 100 kW up to 9.6 MW

Liebert® EXL features a transformer-free design with full IGBT three-level double conversion technology, providing extraordinary savings on installation and running costs, while at the same time delivering first class load protection.

Liebert EXL also features a full IGBT three-level rectifier allowing for electrical infrastructure cost saving, reducing the size of gensets, circuit protection, cabling and transformers.

### Flexibility and Compatibility

Liebert EXL can be fully adapted to meet diverse system requirements in terms of power capacity and redundancy allowing for different system designs, thus ensuring maximum flexibility:

- Output Power Factor up to 1
- No power derating from 0.4 lagging to 0.7 leading
- Optimum space/power ratio

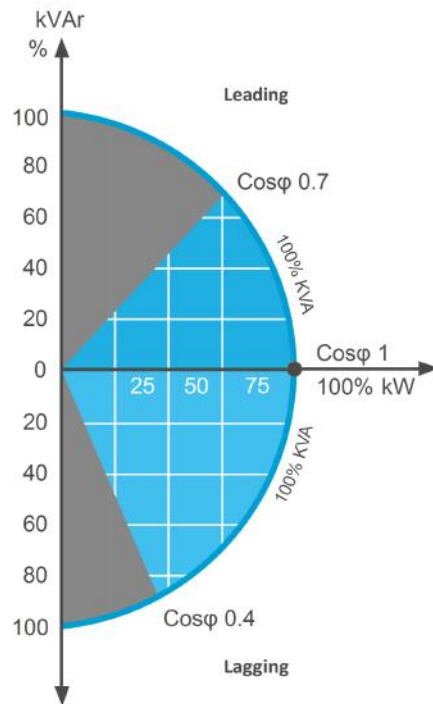

**Maximized active power, high efficiency and complete compatibility for modern, mission critical IT loads.**

### Features and Performance

- Transformer-free design
- Full IGBT three-level NPC2 topology
- Excellent input performances:
  - PF > 0.99
  - THDi < 3%
- Automatic output power upgrade of up to +10%
- Three and four wire electrical compatibility
- Centralized and distributed parallel capabilities
- Seismic compliance



## Improved Efficiency

Liebert® EXL delivers an outstanding double conversion efficiency of up to 97%, which further increases up to 99% with the dynamic online mode, consequently reducing operating costs and energy dissipation (kW) to a minimum. This significantly minimizes the consumption of the cooling system, providing an overall TCO reduction and rapid payback time.

Furthermore, through its intelligent ECO mode efficiency and the intelligent paralleling feature Liebert EXL can optimize efficiency even at partial load achieving additional superior cost savings.

Liebert EXL levels of efficiency and consequent electricity cost savings can be attributed to:

- Latest generation IGBT
- Adoption of a three-level NPC2 topology for both rectifier and inverter
- DC controlled fan speed
- Intelligent paralleling mode
- Advanced digital technology and fast transfer

The seamless activation of Liebert EXL's functioning modes ensures the highest level of efficiency without compromising power quality and availability.

The dynamic online mode ensures Class 1 output performance under most stringent conditions:

- Network fault (voltage variation, high/low impedance mains failures)
- Load fault (short circuit downstream of the UPS)
- Type of load connected (PDU transformer)

The unit is able to discriminate between various types of interferences and rapidly respond, while at the same time ensuring compatibility with downstream equipment such as servers, transformers, STS or mechanical loads.

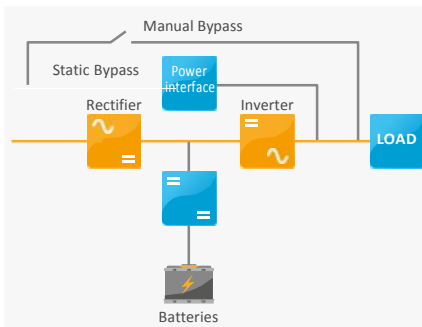

### Maximum Power Control (VFI)

Provides the highest level of power conditioning and protects the load from all electrical network disturbances.

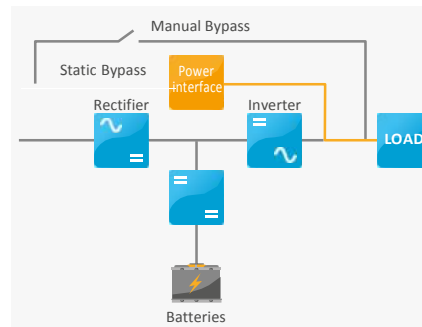

### Maximum Energy Saving (VFD)

Detects when conditioning is not required and allows the energy flow to pass through the bypass line.

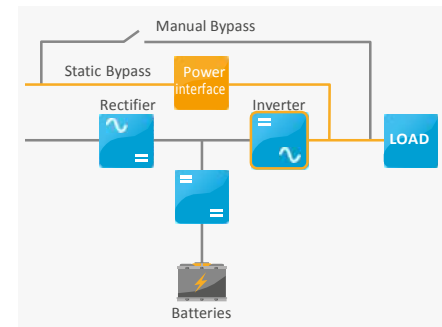

### Dynamic Online, High Efficiency & Power Conditioning (VI)

Compensates the load THDi, PF and mains sags and swells, ensuring fast transfer output performance.

## Dynamic Online mode: No more availability tradeoff with efficiency

Dynamic Online mode is the latest high efficiency mode of operation offered by Vertiv, developed for those that do not want to trade off any level of availability for incremental gains in efficiency.

Dynamic Online mode enables operating efficiency up to 99% without sacrificing availability. In fact, while in this mode, the inverter can instantaneously assume the load and maintain the output voltage within the IEC 62040 Class 1 specification, thus offering the same level of availability typically achieved in a double conversion operating mode.

Dynamic Online mode is therefore able to combine the superior availability of a double conversion operating mode with the excellent energy cost savings of a high efficiency mode for a reduced total cost of ownership.

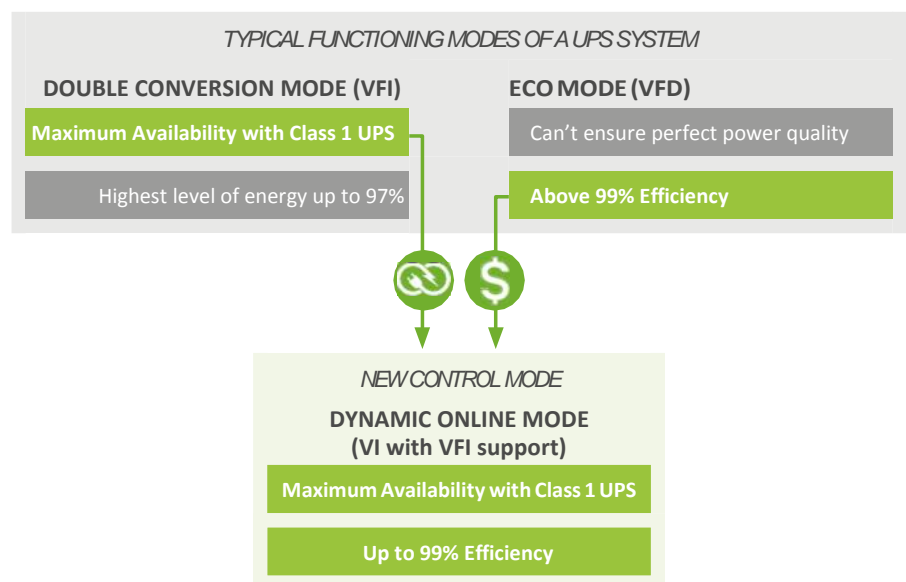

## Intelligent Paralleling

### Liebert® EXL Intelligent Paralleling Feature

Activating the intelligent paralleling feature optimizes efficiency at partial load, thus achieving superior running cost savings. Enabling this feature allows the system to automatically adapt capacity to meet immediate load requirements by switching excess units to standby mode, while ensuring continued system availability. Furthermore, the Intelligent Paralleling feature allows each Liebert EXL unit to operate in standby mode for the same amount of time, ensuring an equal life-span of module components.

This intelligent paralleling feature further maximizes Liebert EXL's double conversion efficiency at partial load and allows for an overall energy dissipation and TCO reduction.

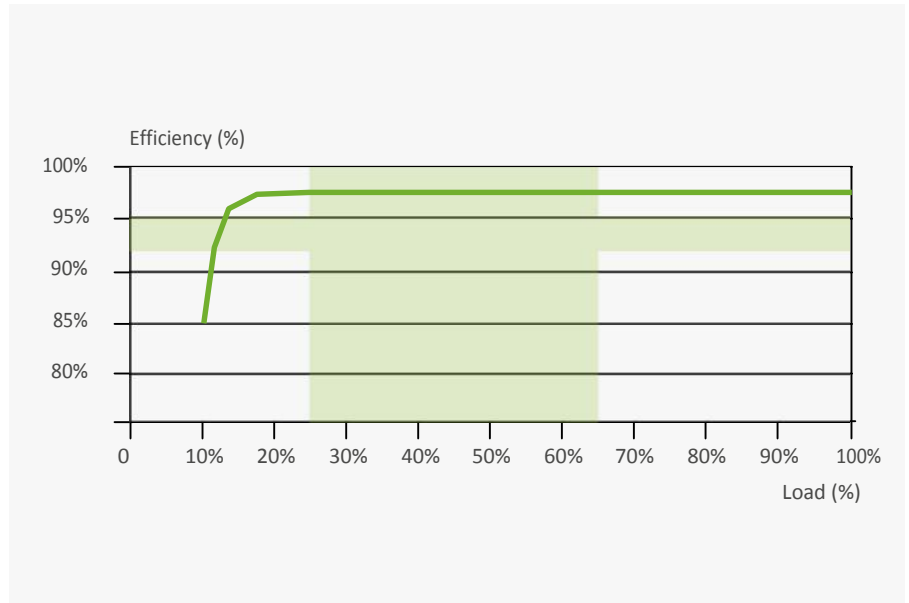

Liebert EXL AC/AC efficiency with Intelligent Paralleling feature



33%

Four units at 33% load each = 96% efficiency.



65%

Liebert EXL Intelligent Paralleling:  
two units at 65% load each = 96.8% efficiency

## Parallel Configurations

The Liebert® EXL can be connected with up to 8 units in parallel, where single units can be serviced while the remaining units continue to power the load. A Liebert EXL unit continues to operate even while it's being upgraded to a parallel system due to the upgrade occurring via software settings. Furthermore, Liebert EXL is backward compatible with the previous 80-NET generation, so as to facilitate any legacy system power upgrade. Liebert EXL can support both distributed and centralized parallel configurations providing maximum energy saving via double conversion and intelligent ECO mode, allowing to operate with a system efficiency of up to 99%.

### Distributed Parallel Configuration

Paralleling single Liebert EXL units offers advanced scalability. In a distributed parallel configuration, each unit has a dedicated static bypass switch, providing parallel operation without the need for a system control cabinet, thus reducing initial installation costs.

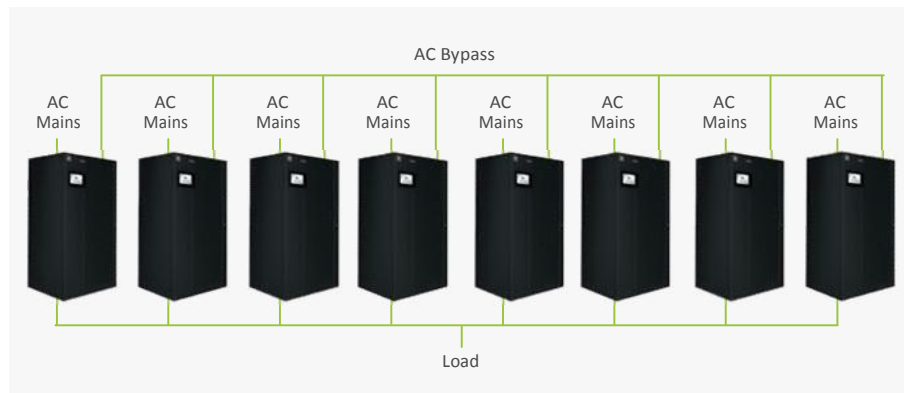

*Liebert EXL distributed parallel configuration, with 8 UPS units in parallel*

### Centralized Parallel Configuration

With the Liebert EXL's centralized parallel configuration, the internal static bypass switch of each unit is disabled and an external Main Static Switch (MSS) rated for the desired maximum capacity, is installed. Therefore, the reserve supply to the loads operates via one central piece of equipment (MSS).

The MSS can easily be integrated into any switchgear, thus simplifying cabling and installation. System level commands are given to the MSS via its integrated touch screen display.

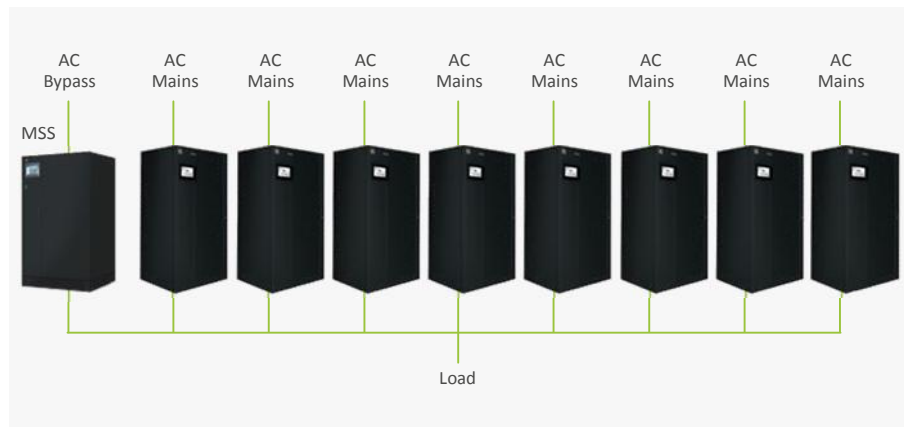

*Liebert EXL centralized parallel configuration, with MSS plus 8 UPS units in parallel*

## User Interface and Advanced Diagnostic

Liebert® EXL makes your mission critical space a peaceful place through its advanced diagnostic capability, measuring and logging, enhanced event analysis as well as an intelligent colored multi-language touch screen display.

Liebert EXL advanced DSP control platform together with the patented VectorControl technology enables increased performance of three-level power converters and real time control of output power quality, guaranteeing continuous operation and premium protection for your customer's business.

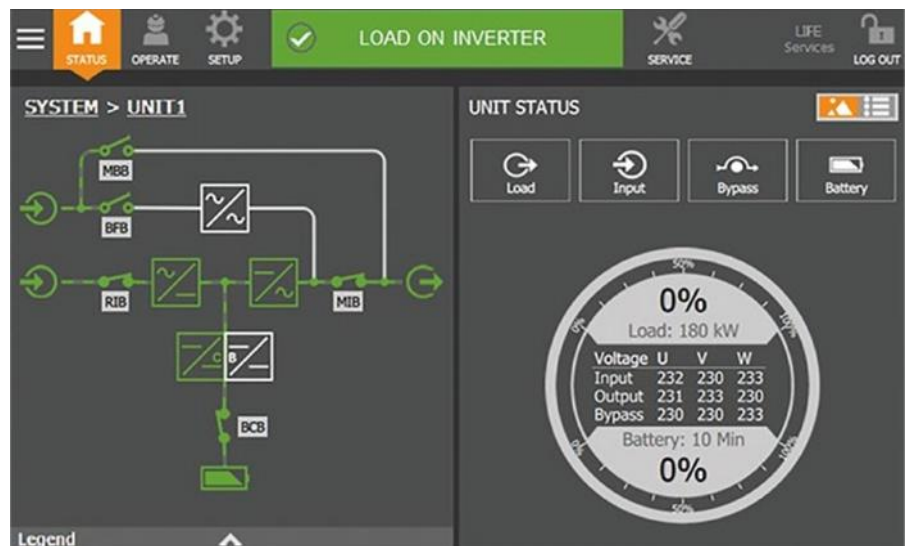

### Bypass Input

Voltage and frequency measurements.

### Mains Input

Current, voltage and frequency values of the three input phases.

### Warning/fault

Alerts of anomalies on bypass, rectifier, inverter, booster/charger, battery and load.

### Events log

Date and time of important UPS events, alarms and other warnings.

### Measurements

Voltage, current and frequency values of each internal functional block.

### Battery

Status/values including temperature, cell voltage, capacity run time and testing.

### Vertiv™ LIFE™ Services

Status of Vertiv LIFE Services connections and calls.

### Tools

LCD settings and language selection.

### Output

Voltage, current, frequency, and battery measurements.



## Reduced TCO

### Neutral Carbon Footprint

Liebert® EXL's new generation architecture has been designed to reduce energy and heat dissipation, consequently minimizing the demand and consumption of air conditioning systems.

The combination of these factors, coupled with a double conversion efficiency of up to 97%, reduces CO<sub>2</sub> emissions to a minimum. This contributes to ensuring that your customers' data centers are a step closer to meeting the industry's environmental and efficiency compliance standards.



**97%**

Double Conversion

**Efficiency**



**CO<sub>2</sub>**

**950 tons**

of CO<sub>2</sub> saved every year

Advanced control diagnostic, excellent operating efficiency, intelligent paralleling feature, minimum footprint and high energy density make Liebert EXL the perfect UPS to deliver secure power to all mission critical applications, maximum energy saving and rapid return on investment.

Liebert EXL provides system capacity from 100 kW up to 9.6 MW which can be adapted according to diverse design requirements in terms of flexibility, redundancy and system reliability.

Furthermore, its high power density in a minimum space allows customers to maximize the number of racks and servers housed in their data center, thus granting more space for IT equipment.

The Liebert EXL technology, has brought extraordinary benefits in terms of:

- ▣ Zero impact on upstream infrastructure
- ▣ Perfect compatibility with modern mission critical loads
- ▣ Enhanced performances for maximum energy saving
- ▣ CO<sub>2</sub> emission reduction
- ▣ Maximum system flexibility for all installations
- ▣ Reduced TCO

## Vertiv™ LIFE™ Services Remote Diagnostic and Preventive Monitoring

Vertiv's service program is designed to ensure that your critical power protection system is maintained in an optimum state of readiness at all times.



The **Vertiv™ LIFE™ Services** Remote Diagnostic and Preventive Monitoring provides early warning of UPS conditions and out of tolerances. This allows effective proactive maintenance, fast incident response and remote trouble shooting, giving customers complete security and peace of mind. With Vertiv LIFE Services you will benefit from:

### Uptime Assurance

Constant monitoring of UPS parameters, thus maximizing the system's availability.

### First Time Fix Rate

Pro-active monitoring and data measuring ensure that when our customer engineers are dispatched on-site, they arrive prepared for first time resolution.

### Proactive Analysis

From Vertiv LIFE Services centers, our experts proactively analyze the data and trends of your equipment, to recommend actions to ensure their best performance.

### Minimized Total Cost of Ownership of Your Equipment

The continuous monitoring of all relevant parameters in turn maximizes unit performance, reduces on-site maintenance and extends the life of your equipment.

### Fast Incident Response

Vertiv LIFE Services allows for immediate definition of the best course of action, as a result of the regular communication between your Liebert® EXL system and our Vertiv LIFE Services centers.

### Reporting

You will receive a comprehensive report detailing the working order of your equipment and its operational performance.

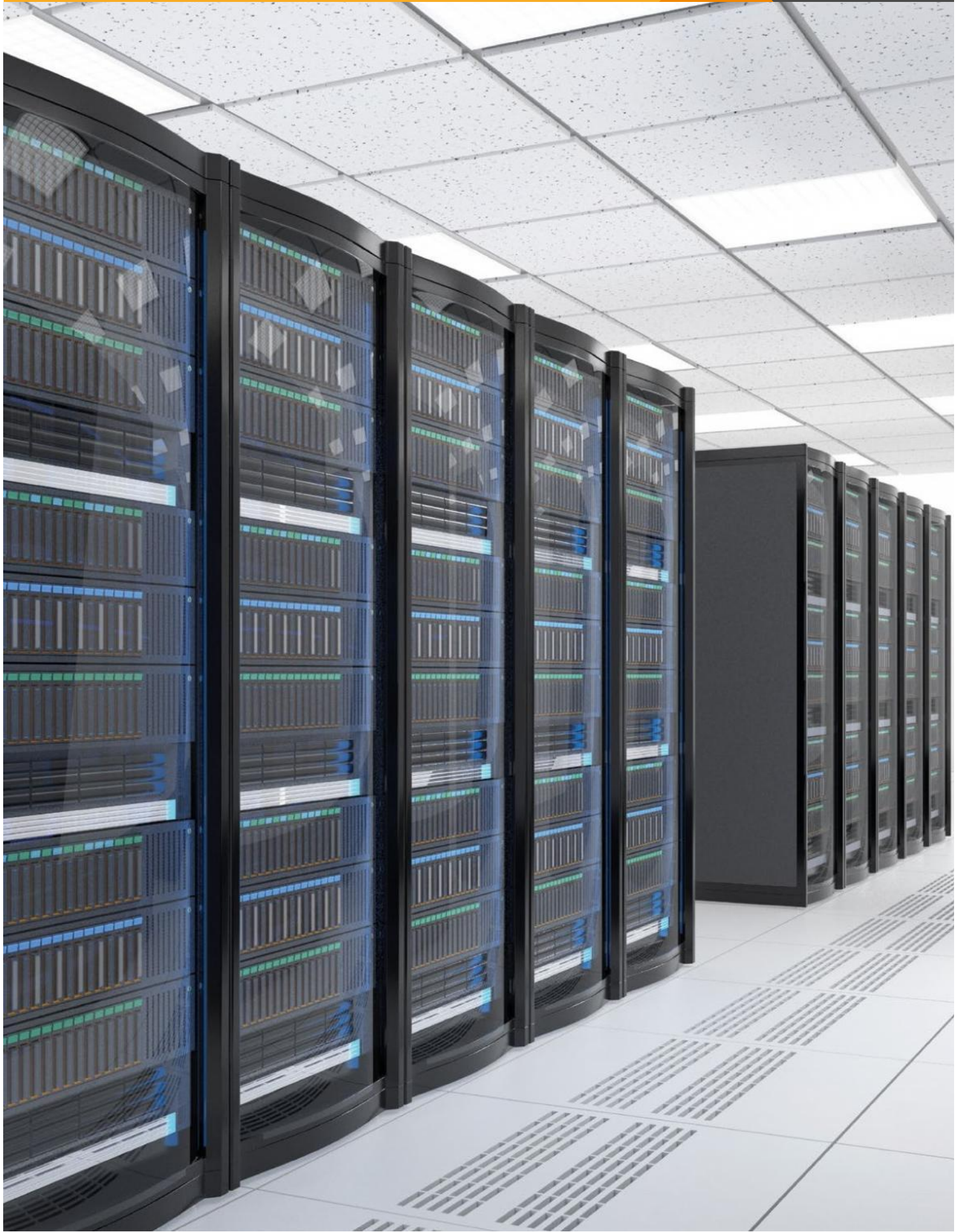



## Customer Monitoring Interfaces

### LCD Touch Screen Features

- High security access with separate password levels for users and service engineers
- User-friendly graphical interface
- Single-line mimic diagram showing system status
- Dedicated warning/fault and event log page used to monitor USP status and important events
- Dedicated measurements page for all UPS internal functional blocks

### Hardware Connectivity

Liebert® EXL allows for the monitoring and control of networked UPS, through different protocol options:

- The integration of UPS with Building Monitoring and Automation Systems via MODBUS RTU, MODBUS/TCP or JBUS protocols
- The integration of UPS in Network Management Systems through SNMP protocol
- Two slots for additional connectivity cards are available for specific protocol requirements.

### Software Connectivity

Liebert® Nform™ will monitor the Liebert EXL via SNMP protocol. Authenticated alarm management, trend analysis and event notification delivers a comprehensive monitoring solution. Available in a variety of versions to suit anything from small computer rooms to multiple location distributed IT networks, Liebert Nform enables:

- Condition based system state recording
- Alarm event exporting to disk
- SMTP email
- Execution of external program
- Shut down clients

**Liebert SiteScan®** is a centralized site monitoring system which ensures maximum visibility and availability of critical operations. Liebert SiteScan Web allows users to virtually monitor and control any piece of critical support equipment. Its features include real-time monitoring and control, data analysis, trend reporting, and event management.

## VERTIV™ TRELLIS™ PLATFORM

Vertiv's *Trellis* platform is a real-time infrastructure optimization platform that enables the unified management of data centre IT and facilities infrastructure.

The *Trellis* platform software can manage capacity, track inventory, plan changes, visualize configurations, analyze and calculate energy usage, and optimize cooling and power equipment.

The *Trellis* platform monitors the data center, providing a thorough understanding of system dependencies to help IT and facilities organizations keep the data center running at peak performance. This unified and complete solution, delivers the power to see the real situation in your data center, make the right decision and take action with confidence.



## Customer Experience Center

**Vertiv™ state-of-the-art Customer Experience Center located in Castel Guelfo (Bologna - Italy), enables our customers to experience first-hand a wide variety of data center technologies, supported by constant consultation from R&D and engineering specialists.**

Customers visiting the center will be able to witness pre-installation demonstrations, covering the technical performance, interoperability and efficiency of Vertiv UPS systems under real field conditions. These processes can be experienced from the facility's control room, where real-time performance measurements and reporting will be available while providing full visibility of the demonstration area. The center can host simultaneous tests at full load of up to 4000 A.

The customer validation area specifically dedicated to UPS consists of four testing stations, each one providing up

to 1.2 MVA of capacity. Testing includes individual modules, as well as complete power systems, with the added possibility of the customer's switchgear support systems being connected, thus guaranteeing smooth, rapid installation and commissioning of large power systems.

Testing is also customized based on the complexity, size and number of UPS components in the configuration.

Our Customer Experience Center offers three validation experiences:

- 📌 **Demo** - carried out on new products to demonstrate UPS performance
- 📌 **Standard** - validation test showing UPS standard technical performances in compliance with UPS catalogue and IEC 62040-3 standards
- 📌 **Customized** - session tailored to validating customer's specific technical performance needs.

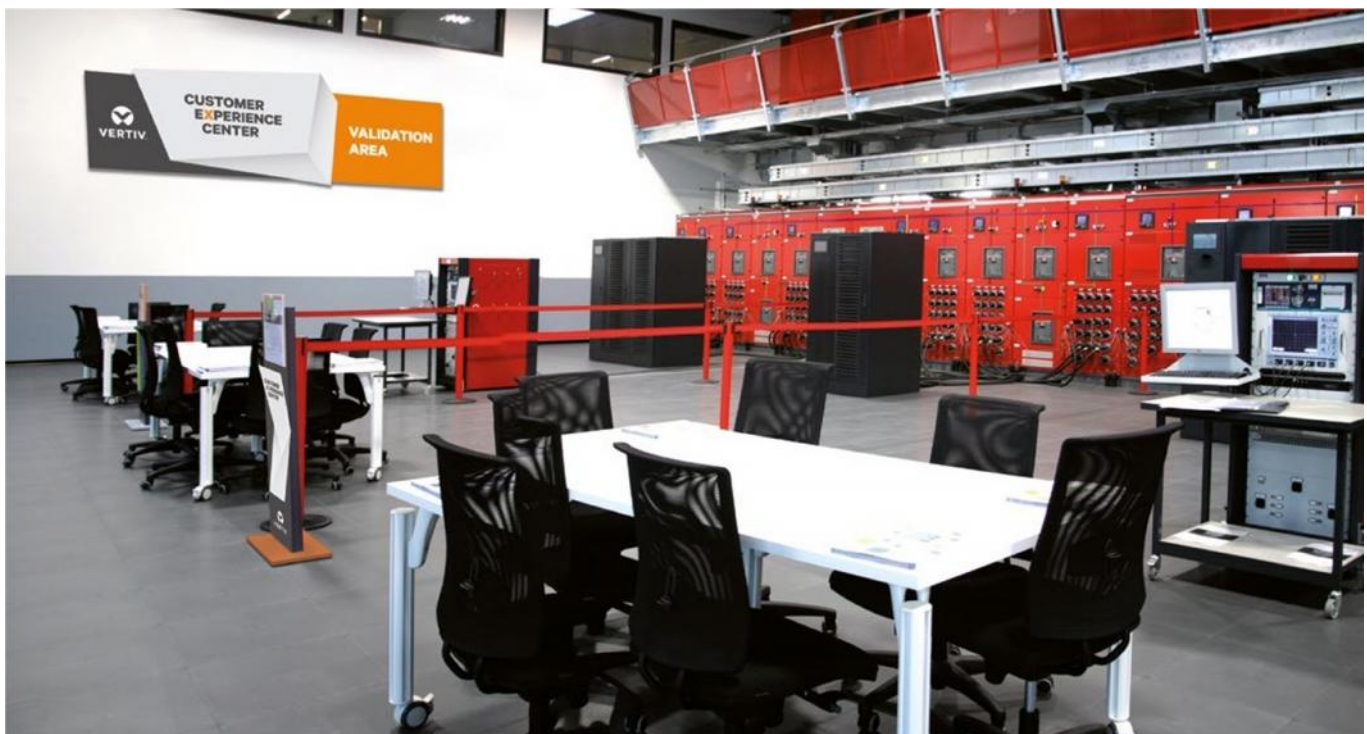

## Liebert® EXL S1 Specifications

TECHNICAL SPECIFICATIONS											
UPS Rating (kVA)	100	120	160	200	300	400	500	600	800	1000	1200
Output active power at 35 °C*(kW)	100	120	160	200	300	400	500	600	800	1000	1200
Output active power at 40 °C (kW)	90	108	144	180	270	360	450	540	720	900	1080
INPUT											
Nominal mains input voltage / voltage range* (V)	400 (200 to 460), 3Ph or 3Ph + N										
Nominal bypass input voltage / voltage range* (V)	400 (380/415 selectable), 3Ph or 3Ph + N										
Nominal frequency / frequency tolerance (Hz)	50±10%(60 selectable)										
Input Power Factor	≥ 0.99										
Input current distortion (THDi) (%)	≤3										
OUTPUT											
Nominal output voltage (V)	400 (380/415 selectable), 3Ph or 3Ph + N										
Nominal output frequency (Hz)	50 (60 selectable)										
Output voltage stability by load variation 0-100% (%)	±1										
▣ static	Complies with IEC/EN 62040-3, Class 1										
▣ dynamic	Complies with IEC/EN 62040-3, Class 1										
Output frequency stability	±2 (2, 3, 4, 5 selectable)										
▣ synchronized with bypass mains (%)	±0.1										
▣ synchronized with internal clock (%)	±0.1										
Inverter Overload Capacity*	110% continuous, 125% for 10mins, 150% for 1min										
Short circuit current for 200 ms	2.2 In										
Load crest factor handled without derating the ups (Ipk/Irms)	3:1										
Compatibility with loads	Any power factor (leading or lagging) up to 1										
BATTERY											
Permissible battery voltage range (V)	396 to 700										
Float voltage for VRLA @ 20 °C (V/cell)	2,27										
End cell voltage for VRLA (V/cell)	1.65										
Float Voltage stability in steady state condition (%)	≤1										
DC ripple voltage without battery (%)	≤1										
Battery Switch	Not included										
BYPASS											
Manual Maintenance Bypass	Included 100-500 kW					Not included 600-1200 kW					
GENERAL AND SYSTEM DATA											
Classification according to IEC/EN 62040-3	VFI-SS-111										
Operating Temperature (°C)	0-40										
Maximum relative humidity @ 20 °C (non condensing) (%)	up to 95										
Protection degree with open doors	IP 20										
Frame colour (RAL scale)	7021										
Noise @ 1 metre as per ISO 3746 (dBA ± 2dBA)	65	67	69	71	76	78					
	64 dBA @partial load	65 dBA @partial load			70 dBA @partial load		72 dBA @partial load				
Parallel configuration	up to 8 units in parallel										
Access	Front and Top (no rear access required)										
▣ VFI efficiency	up to 97%										
▣ Dynamic Online (VI) efficiency	up to 99%										
▣ VFD efficiency	above 99%										
DIMENSION AND WEIGHT											
Height (mm)	1950										
Width (mm)	500	750	1000	1250	1600	2000	2650				
Depth (mm)	900										
Net Weight (kg)	370	510	725	990	1135	1550	2275				

\*Conditions apply

# Data Center Infrastructure for Large Applications

## Static Transfer Switch



- **Liebert® CROSS**
- ☒ Ensures redundant power for critical loads, switching between two independent power sources
- ☒ Solid-state transfer switch available as 2/3/4P versions with full PF range to guarantee compatibility with all load types
- ☒ Extremely reliable and flexible architecture.

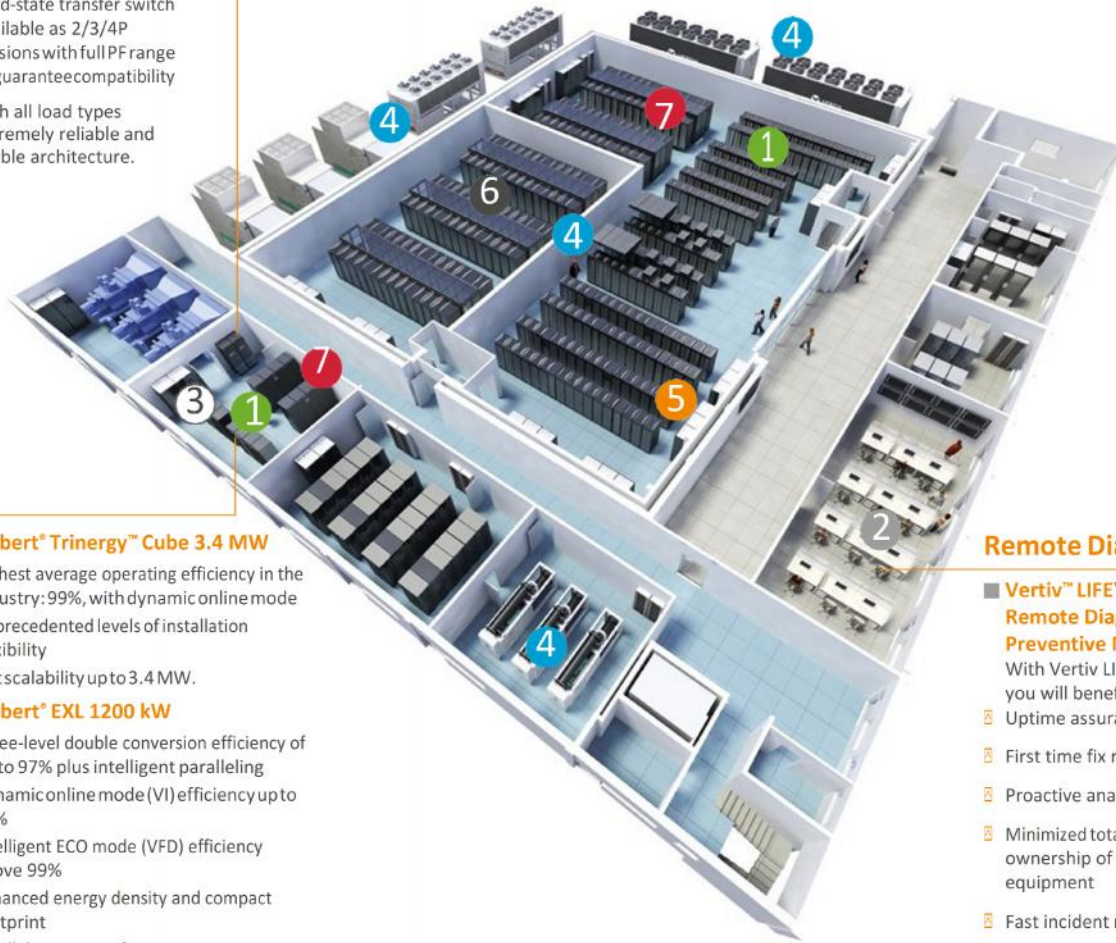

## UPS



- **Liebert® Trinergy™ Cube 3.4 MW**
- ☒ Highest average operating efficiency in the industry: 99%, with dynamic online mode
- ☒ Unprecedented levels of installation flexibility
- ☒ Hotscalability up to 3.4 MW.



- **Liebert® EXL 1200 kW**
- ☒ Three-level double conversion efficiency of up to 97% plus intelligent paralleling
- ☒ Dynamic online mode (VI) efficiency up to 99%
- ☒ Intelligent ECO mode (VFD) efficiency above 99%
- ☒ Enhanced energy density and compact footprint
- ☒ Parallel system configuration up to 8 units with both centralized and distributed parallel capabilities.



- **Liebert® APM 600 kW**
- ☒ Versatile and modular UPS for row and room applications
- ☒ Designed to operate with a maximum energy efficiency of up to 96.3%
- ☒ Hot-swappable power modules
- ☒ Flexible configuration with 30 kW and 50 kW power module capacities.

## Remote Diagnostics

- **Vertiv™ LIFE™ Services Remote Diagnostic and Preventive Monitoring**
- ☒ With Vertiv LIFE Services you will benefit from:
  - ☒ Uptime assurance
  - ☒ First time fix rate
  - ☒ Proactive analysis
  - ☒ Minimized total cost of ownership of your equipment
  - ☒ Fast incident response
  - ☒ Reporting.

1 AC Power

2 Infrastructure Management & Monitoring

3 Power Switching & Controls

4 Thermal Management

5 Racks & Integrated Cabinets

6 Surge Protection

7 DC Power



**COSTA POWER INDUSTRIES PVT. LTD.**

209, 2nd Floor, Infinity Business Park, Behind Pendharkar College,  
MIDC Phase - 1, Dombivli(E), Thane - 421023.  
Phone No. - 9820710392 / 9372217661.  
Email - sales@upsbatteriesindia.com / sunil@upsbatteriesindia.com.