

Panasonic

ideas for life

LC-P12100

For standby power supplies
 Expected trickle life: 6 years at 25°C
 10 years at 20°C



※Contents indicated (including the recycle marking, etc) are subject to change without notice.

■ Dimensions(mm)

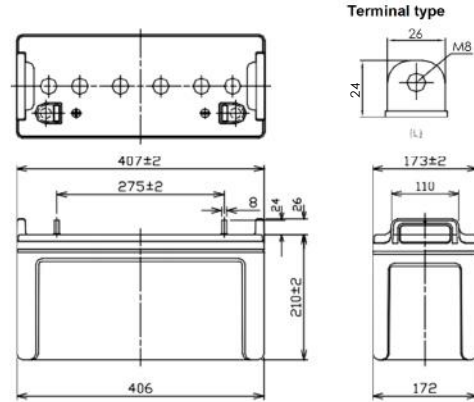

Battery case resin: Flame-retardant (UL94V-0)

■ Specification

Nominal Voltage		12V
Rated Capacity(20HR)		100Ah
Dimensions	Length	407 mm
	Width	173 mm
	Height	210 mm
	Total height	236 mm
Approx. Mass		29.0 kg
Terminal		M8 threaded post

■ Characteristics

Capacity (25 °C)	20 hour rate	100Ah
	10 hour rate	90Ah
	3 hour rate	76Ah
	1 hour rate	56Ah
Internal Resistance (25 °C)	Fully charged battery	5 mΩ
Temperature Dependency of Capacity (20 hour rate)	40 °C	102%
	25 °C	100%
	0 °C	85%
	-15 °C	65%
Self Discharge (25 °C)	After 3 months	91%
	After 6 months	82%
	After 12 months	64%

■ Duration of discharge vs. discharge current

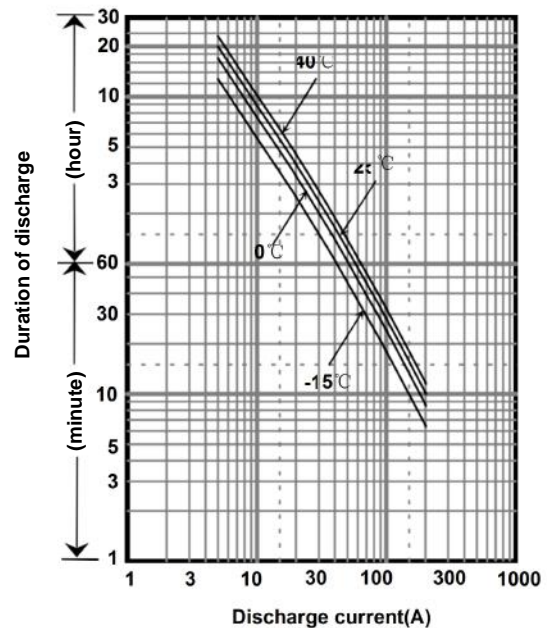

■ Watt Table(25°C)

Cut-off V	(Wattage/Battery)															
	5min	10min	15min	20min	30min	45min	1h	1.5h	2h	3h	4h	5h	6h	10h	20h	
9.6V	2610	2094	1769	1500	1156	843	681	493	407	280	215	175	147	92.3	47.0	
9.9V	2564	2069	1751	1493	1143	822	663	480	396	275	211	169	143	89.2	46.7	
10.2V	2403	2016	1715	1468	1131	815	645	471	391	270	206	164	139	88.1	46.1	
10.5V	2153	1868	1596	1394	1105	802	627	461	383	265	204	162	137	87.1	45.8	
10.8V	1903	1633	1460	1330	1046	773	618	439	374	260	199	159	134	86.0	45.5	

■ Ampere Table(25°C)

Cut-off V	(Ampere/Battery)															
	5min	10min	15min	20min	30min	45min	1h	1.5h	2h	3h	4h	5h	6h	10h	20h	
9.6V	250	194	153	129	97.3	74.1	59.4	43.8	37.6	26.7	20.7	17.6	14.7	9.41	5.13	
9.9V	247	192	152	127	96.2	72.3	58.6	42.7	37.5	26.2	20.6	17.1	14.5	9.31	5.03	
10.2V	241	187	149	126	95.1	71.6	57.4	41.8	36.5	25.9	20.4	17.0	14.3	9.21	5.01	
10.5V	223	173	138	119	93.0	70.5	56.3	41.0	35.2	25.5	20.3	16.8	14.1	9.10	5.00	
10.8V	195	151	127	114	88.0	68.0	54.0	39.1	32.9	24.5	19.6	16.1	13.9	9.00	4.92	

■ **Charging Method** (25°C)

Trickle use	Control voltage:13.6-13.8V Initial current:15.0A or smaller
-------------	--

■ **Cut off voltage**

Discharge current	5.00A-20.0A	20.0A-50.0A	50.0A-100A	100A-200A	200A-300A
Cut off voltage(V)	10.5	10.2	9.9	9.3	8.7

■ **Influence of Temperature on Trickle life**

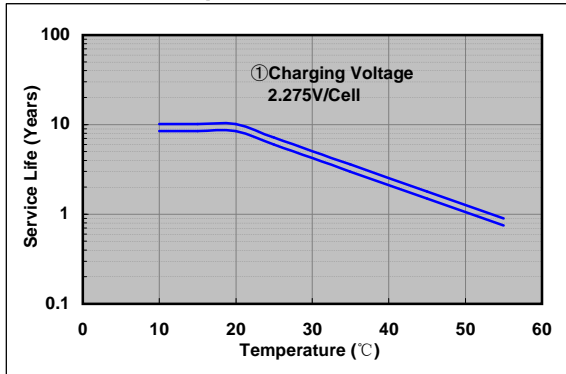

■ **Residual capacity test result**

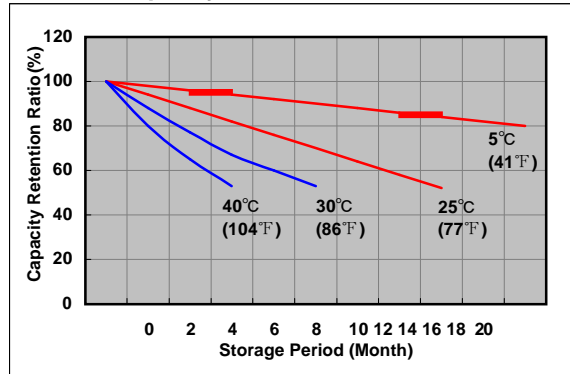

■ **Constant-voltage constant-current charge characteristics for Trickle use**

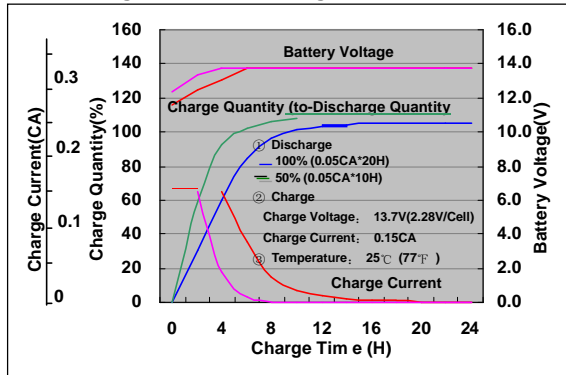

■ **Discharge capacity by temperature and by discharge current**

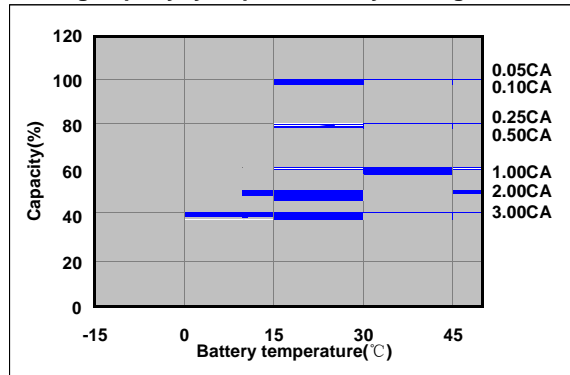

■ **Discharge characteristics(25°C)**

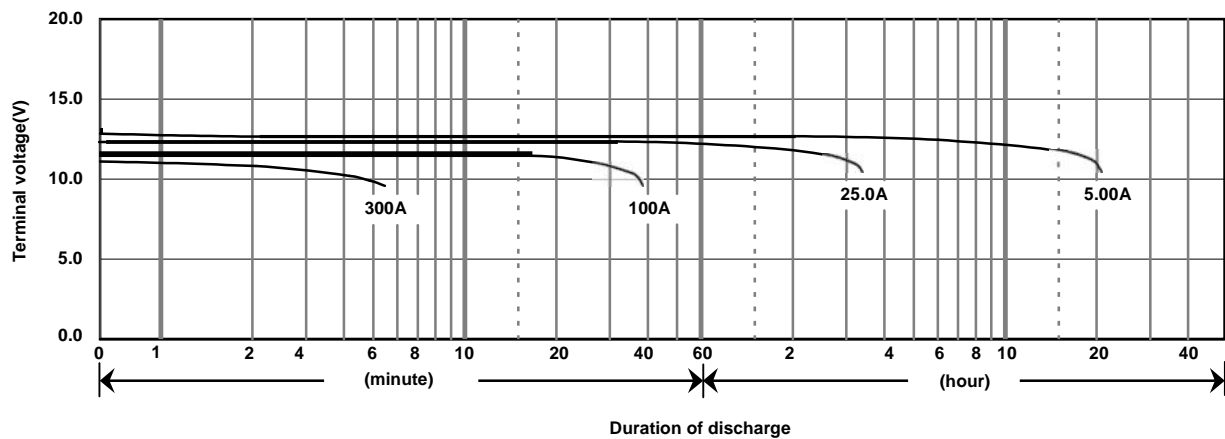

Costa Power Industries Pvt Ltd.

201,Sainath Prasad Building,Opp Kasturi Plaza, Station Road,Dombivali - East 421201.

Contact No. 9372217661 / 9820710392

sales@upsbatteriesindia.com / sunil@upsbatteriesindia.com