

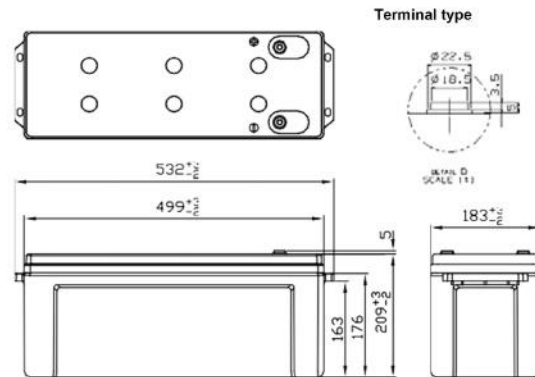

※Contents indicated (including the recycle marking, etc) are subject to change without notice.

### ■ Dimensions(mm)



Battery case resin: Flame-retardant (UL94V-0)

### ■ Specification

Nominal Voltage		12V
Rated Capacity(20HR)		150Ah
Dimensions	Length	532 mm
	Width	183 mm
	Height	209 mm
	Total height	214 mm
Approx. Mass		43.0 kg
Terminal		M8 threaded post

### ■ Characteristics

Capacity (25 °C)	20 hour rate	150Ah
	10 hour rate	135Ah
	3 hour rate	119Ah
	1 hour rate	88Ah
Internal Resistance (25 °C)	Fully charged battery	4 m
Temperature Dependency of Capacity (20 hour rate)	40 °C	102%
	25 °C	100%
	0 °C	85%
	-15 °C	65%
Self Discharge (25 °C)	After 3 months	91%
	After 6 months	82%
	After 12 months	64%

### ■ Duration of discharge vs. discharge current

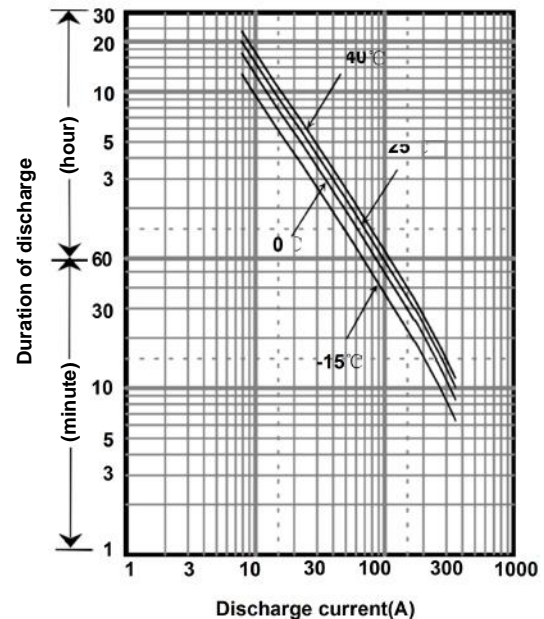

### ■ Watt Table(25°C)

Cut-off V	(Wattage/Battery)															
	5min	10min	15min	20min	30min	45min	1h	1.5h	2h	3h	4h	5h	6h	10h	20h	
9.6V	5040	3780	3000	2390	1774	1310	1046	791	576	420	328	268	232	160	90.3	
9.9V	4925	3689	2923	2334	1727	1276	1013	763	585	428	334	274	235	161	90.3	
10.2V	4340	3405	2833	2261	1672	1238	976	724	596	437	342	281	240	163	91.2	
10.5V	3917	3216	2751	2197	1641	1208	947	695	608	444	348	284	242	164	91.2	
10.8V	3432	2839	2661	2149	1601	1163	910	659	592	433	339	278	237	163	91.1	

### ■ Ampere Table(25°C)

Cut-off V	(Ampere/Battery)															
	5min	10min	15min	20min	30min	45min	1h	1.5h	2h	3h	4h	5h	6h	10h	20h	
9.6V	490	350	266	217	164	120	97.2	70.0	59.0	42.1	32.9	27.3	23.0	14.0	7.58	
9.9V	479	342	259	212	159	117	94.1	67.5	58.0	41.3	32.3	26.7	22.6	13.9	7.58	
10.2V	422	315	251	206	154	114	90.7	64.1	56.9	40.4	31.5	26.0	22.2	13.8	7.50	
10.5V	381	298	244	200	151	111	88.0	61.5	55.8	39.8	31.0	25.7	22.0	13.7	7.50	
10.8V	334	263	236	195	148	107	84.6	58.3	54.4	38.8	30.3	25.2	21.6	13.5	7.49	

**Charging Method (25°C)**

Trickle use	Control voltage:13.6-13.8V Initial current:22.5A or smaller
-------------	--

**Cut off voltage**

Discharge current	7.50A-30.0A	30.0A-75.0A	75.0A-150A	150A-300A	300A-450A
Cut off voltage(V)	10.5	10.2	9.9	9.3	8.7

**Influence of Temperature on Trickle life**

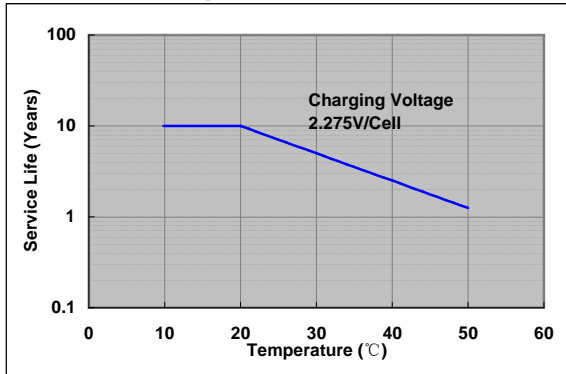

**Residual capacity test result**

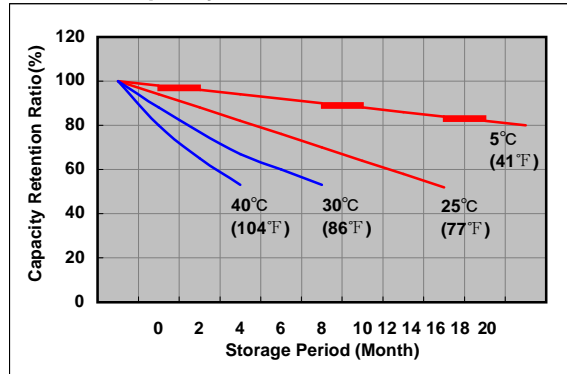

**Constant-voltage constant-current charge characteristics for Trickle use**

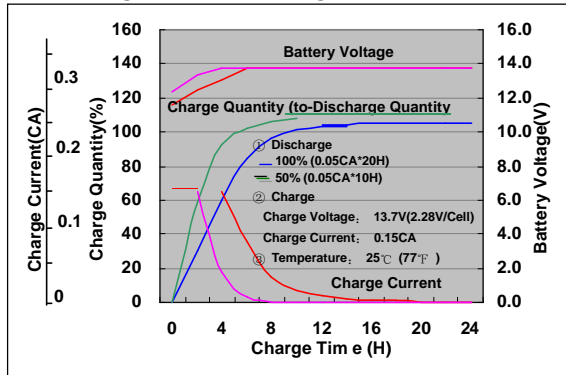

**Discharge capacity by temperature and by discharge current**

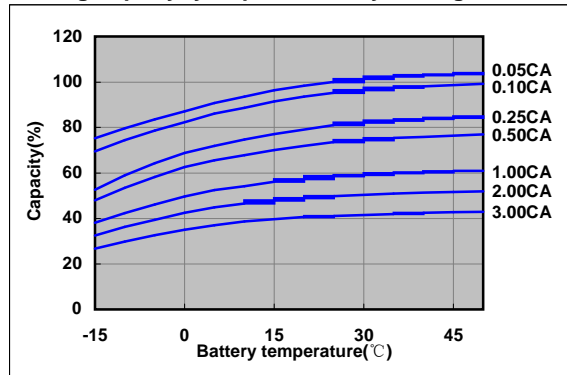

**Discharge characteristics(25°C)**

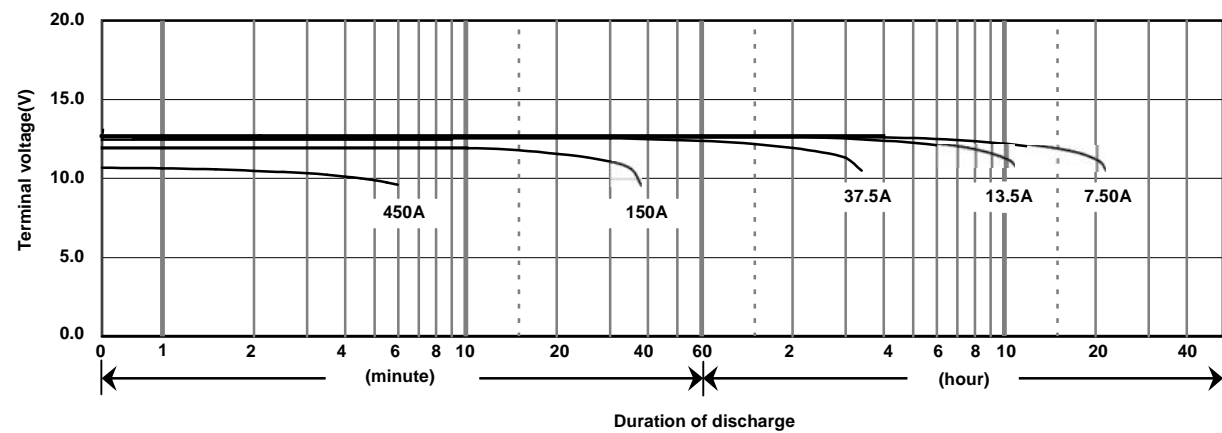

**Costa Power Industries Pvt Ltd.**

201,Sainath Prasad Building,Opp Kasturi Plaza, Station Road,Dombivali - East 421201.

Contact No. 9372217661 / 9820710392

sales@upsbatteriesindia.com / sunil@upsbatteriesindia.com